

Vertical Contact Toaster | VCTM-2



The VCTM-2 is a perfect fit for any operation where premium bun toasting is the objective. This unit combines a small footprint with an auxiliary heater to provide a hotter toasted bun.

The VCTM-2 also features a variable speed motor that provides operations with flexibility for future menu items and allows for light/dark adjustments. It toasts two buns simultaneously and features an individual heel and crown compression knobs that allow operations to easily adjust toast quality.

With the smaller footprint than the standard Vertical Contact Toaster, the VCTM-2 is a perfect fit for any operation where space is limited.

FEATURES

- Toasts two complete buns simultaneously for increased capacity.
- Variable speed motor provides operations with flexibility for future menu items and allows for light/dark adjustments.
- Compact footprint is approximately 30% smaller than the VCT-2000.
- Available with motorized butter wheel to give buns a flavorful toast.
- Available with a wide-mouth opening to accommodate artisan buns.
- Auxiliary heater warms all sides of buns.
- Individual heel and crown compression.
- Digital controller to adjust temperature.

Vertical Contact Toaster | VCTM-2

Dimensions

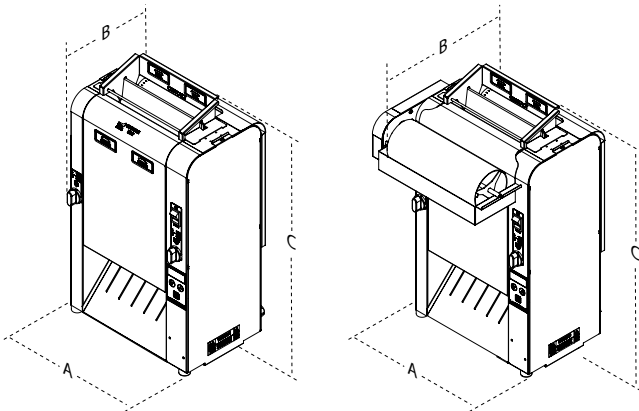

Model & Mfg. No.	Width (A)	Depth (B)	Height (C)
------------------	-----------	-----------	------------

VCTM-2 with Butter Wheel

VCTM-2 9210913 9210914	15 1/4" (387 mm)	14 3/4" (375 mm)	25 1/2" (648 mm)
------------------------------	---------------------	---------------------	---------------------

VCTM-2 without Butter Wheel

VCTM-2 9210915 9210916	14" (356 mm)	10 1/2" (268 mm)	25 1/2" (648 mm)
------------------------------	-----------------	---------------------	---------------------

Electrical Ratings and Plug Configuration

Model & Mfg. No.	Volts	Watts	Hz.	Plug Description
VCTM-2 with Butter Wheel				
VCTM-2 9210913	208-230	3100	50/60	NEMA 6-20P 20 Amp., 250 Volt
VCTM-2 9210914	208-230	3100	50/60	IEC-309 16 Amp., 220-250 Volt
VCTM-2 without Butter Wheel				
VCTM-2 9210915	208-230	3100	50/60	NEMA 6-20P 20 Amp., 250 Volt
VCTM-2 9210916	208-230	3100	50/60	IEC-309 16 Amp., 220-250 Volt

Size Comparison

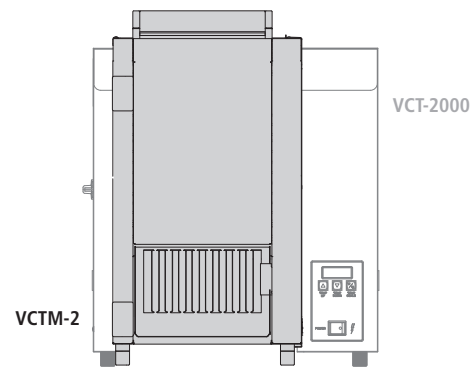

With a footprint that is significantly smaller than the VCT-2000, the VCTM-2 can be easily integrated into any sized operation.

P/N 1020468 01/17